

illumena™ Néo Contrast delivery system

Engineered to Achieve and Maintain Consistent Pressure.

Robust and reliable

A reputation built on quality, with the trusted functionality and durability of the Illumena family.

Pressure tolerance allows ease of use and consistency with microcatheters during angiography.

Engineered for safety

Optional Air Detection Aid & Warning System (ADAWS) identifies an empty syringe or air bolus.

Digital powerhead displays programmed protocol and remaining volume.

Console displays programmed protocol, remaining volume & total volume injected.

Highly visible LED light on powerhead indicates system status.

Broad functionality

Ability to synchronize with major imaging systems to allow bi-directional control.

Switch between operating modes with a single button.

Fill control bar – effortless function at different speeds whether retracting or injecting.

Accommodates original L-F Certified and prefilled syringes.*

Hand and foot switches available.

Hand switch enables single- or multi-injection protocols.

Easy-to-use, intuitive LCD touch screen displays the information you need. Easy to read from any angle, in any light.



Confidence and Performance

High-pressure syringes

Crystal clear for easy air detection.

Designed and certified for use with Illumena Neo.



methapharm
Specialty Pharmaceuticals

Guerbet | 

Technical Specifications

Flow Rate	Angio Mode: 0.1-40.0 mL/sec CT Mode: 0.1-10.0 mL/sec
Pressure Limit	Angio Mode: 75-1200 psi CT Mode: 75-300 psi
Syringe Sizes	150, 200 mL empty syringes 50, 75, 100, 125 mL PFS*
Syringe Heater (optional)	37° C nominal, minimizes the loss of heat from preheated contrast
Scan Delay (CT Mode)	0-300 seconds
Inject Delay	0-300 seconds
X-ray Delay	0-300 seconds
Rate Rise	0-10 seconds
Phase Delay	0-300 seconds
Number of Phases	4
Protocol Memory	99 protocols

Where Available*

Multiple Configurations

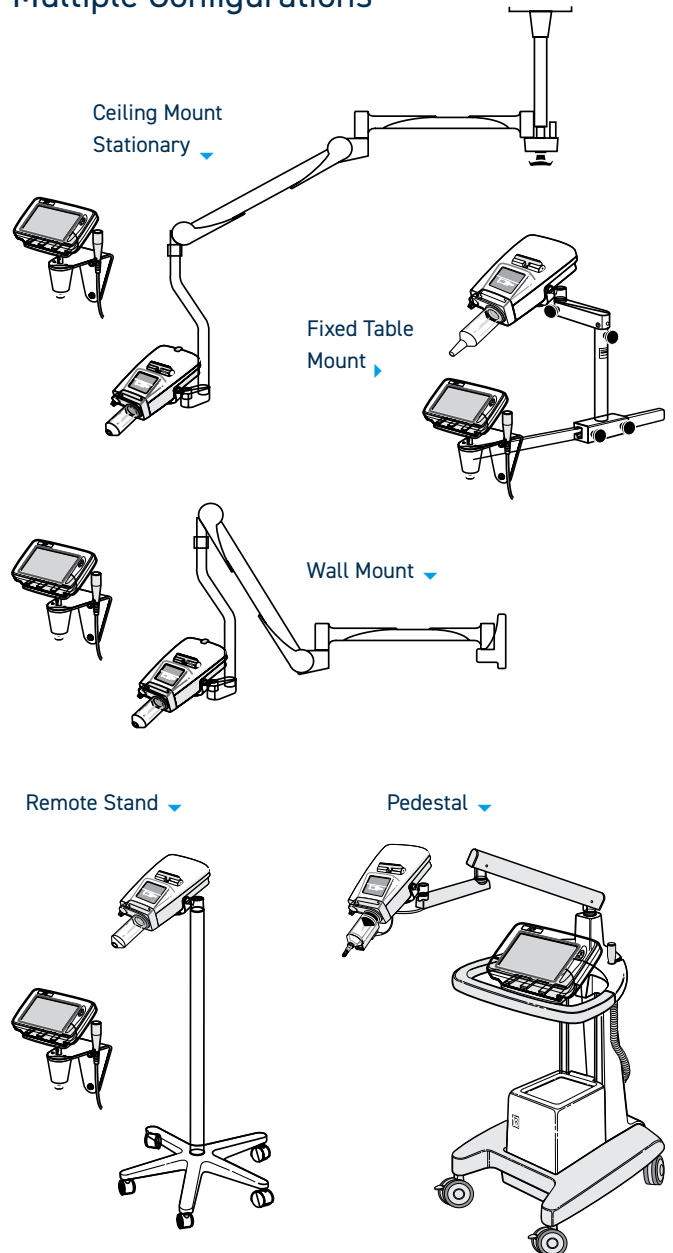

Syringes and Tubing

Code	Description	Size	Maximum Pressure	Qty/Box
900103B	Angio Syringe with Linden-Luer Tip and Handifil straw	150 mL	1200 psi	50 each
900103S	Angio Syringe with Linden-Luer Tip and fill spike	150 mL	1200 psi	50 each
900105S	Angio Syringe with fill spike	200 mL	900 psi	50 each



Sales and Product Inquiries
Tel: 1-800-287-7686
Email: sales@methapharm.com
www.methapharm.com



The Illumena® Néo Contrast Delivery System is a Class II Medical Device in the United States. For complete information about precautions and optimal usage conditions for this device, consult the full instructions for use supplied with each device or with your local Guerbet representative(s). Caution: US Federal Law restricts this device to sale by or on the order of a physician. Illumena® Néo Contrast Delivery System is a registered trademark of Liebel-Flarsheim.

For complete information about precautions and optimal usage conditions, we recommend consulting the instructions for use supplied with the device or by your local Guerbet representative(s).